

# THRU-WALL SCUPPER

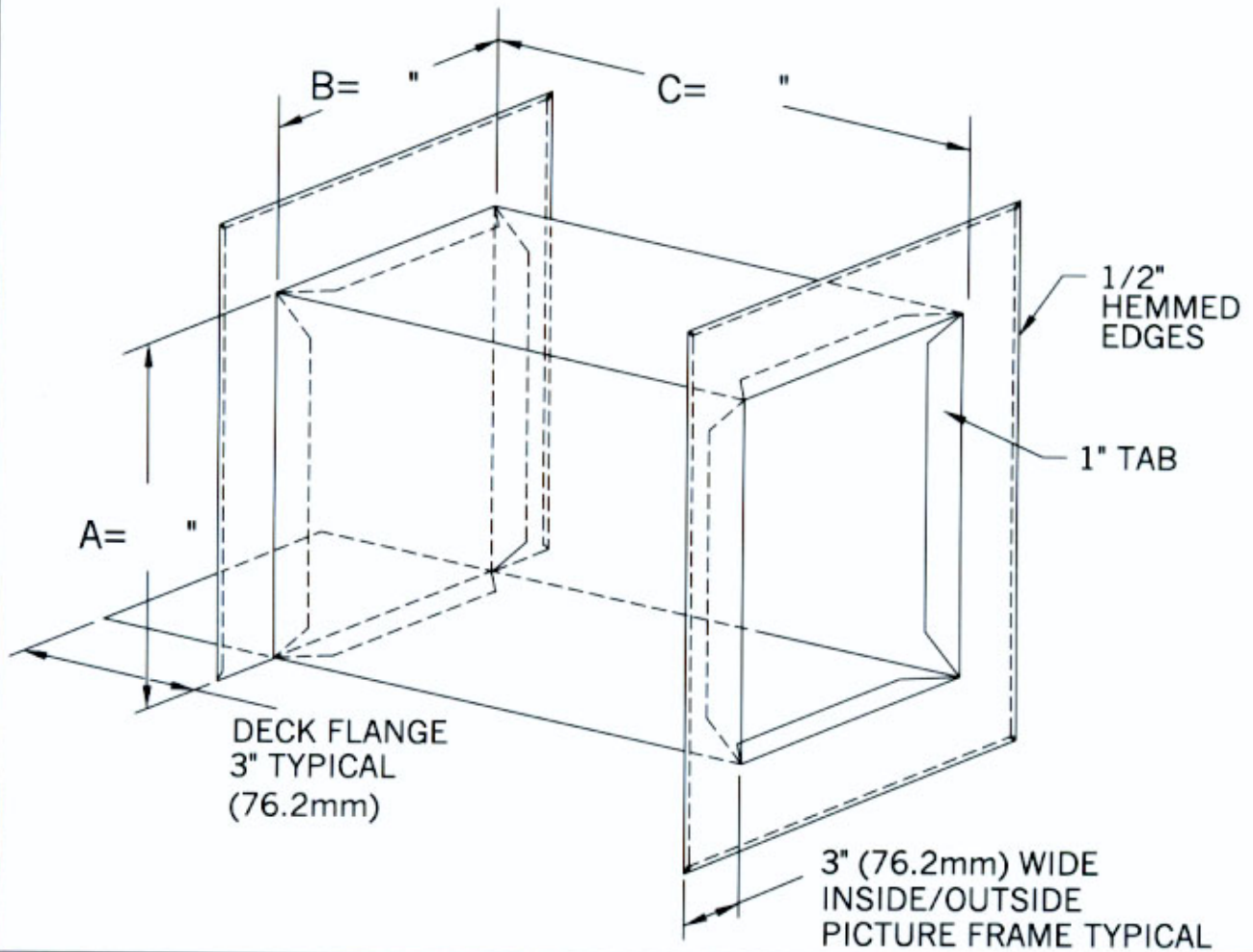

## FABRICATION APPROVAL:

*Architect and /or contractors shall verify all dimensions, sizes, and quantities. All products to be installed in strict accordance with NSMS printed instructions.*

Approved By: \_\_\_\_\_

Date: \_\_\_\_\_

QUANTITIES: \_\_\_\_\_

PROJECT:

ARCHITECT:

CONTRACTOR:

REPRESENTED BY:

## SCUPPER MATERIAL:

- 22 GA.       24 GA. STEEL  
 .032"    .040"    .050"    .063" ALUM.

COLOR \_\_\_\_\_  
FINISH \_\_\_\_\_

**NATIONAL**  
**SHEET METAL SYSTEMS, INC.**

[WWW.NATIONALSHEETMETAL.COM](http://WWW.NATIONALSHEETMETAL.COM)

TOLL FREE : 1-877-GET-METL ( OFFICE )

1-866-298-NSMS ( FAX )

2964 Alcove Drive, Scottdale, GA 30079-0923

Ph# (404) 298-9710 Fax# (404) 298-9720